



DEPARTMENT OF LICENSING AND REGULATORY AFFAIRS
DIRECTOR'S OFFICE
CONSTRUCTION SAFETY STANDARDS

Filed with the Secretary of State on August 31, 1976 (as amended September 30, 1983) (as amended February 13, 1997)
(as amended July 2, 1999)

This amended rule will take effect July 30, 1999

(By authority conferred on the director of the department of consumer and industry services by sections 19 and 21 of Act No. 154 of the Public Acts of 1974, as amended, and Executive Reorganization Order No. 1996-2, being §§408.1019, 408.1021, and 445.2001 of the Michigan Compiled Laws)

R 408.41301 of the Michigan Administrative Code is amended as follows:

PART 13. MOBILE EQUIPMENT

TABLE OF CONTENTS

R 408.41301 Adoption by reference of federal OSHA standard.....	1	(b) Equipment manufactured on or after September 1, 1972	9
1926.600—EQUIPMENT	2	(c) Equipment manufactured before September 1, 1972 ..	9
(a) General requirements	2	(d) Remounting	9
(b) Specific requirements.....	2	(e) Labeling	9
1926.601—MOTOR VEHICLES	2	(f) Machines meeting certain existing governmental requirements	9
(a) Coverage	2	1926.1001—MINIMUM PERFORMANCE CRITERIA FOR ROLLOVER PROTECTIVE STRUCTURES FOR DESIGNATED SCRAPERS, LOADERS, DOZERS, GRADERS, AND CRAWLER TRACTORS.....	10
(b) General requirements	2	(a) General	10
1926.602—MATERIAL HANDLING EQUIPMENT.....	3	(b) The static laboratory test	10
(a) Earthmoving equipment; general	3	(c) Facilities and apparatus	10
(b) Excavating and other equipment.....	4	(d) Vehicle condition.....	10
(c) Lifting and hauling equipment	4	(e) Test procedure	10
(d) Powered industrial truck operator training.....	4	(f) Performance requirements	11
Appendix A--Stability of Powered Industrial Trucks	5	(g) Definitions	13
1926.603—PILE DRIVING EQUIPMENT	7	(h) Source of standard	13
(a) General requirements	7	1926.1002—PROTECTIVE FRAMES (ROLL-OVER PROTECTIVE STRUCTURES, KNOWN AS ROPS) FOR WHEEL-TYPE AGRICULTURAL AND INDUSTRIAL TRACTORS USED IN CONSTRUCTION	14
(b) Pile driving from barges and floats	8	(a) General	14
(c) Pile driving equipment	8	(b) Applicability.....	14
1926.604—SITE CLEARING	8	(j) Definitions applicable to this section	14
(a) General requirements	8	1926.1003 — OVERHEAD PROTECTION FOR OPERATORS OF AGRICULTURAL AND INDUSTRIAL TRACTORS.....	14
(b) Specific requirements.....	8	(a) General	14
1926.605—MARINE OPERATIONS AND EQUIPMENT	8	(b) Overhead protection	15
(a) Material handling operations	8		
(b) Access to barges.....	8		
(c) Working surfaces of barges	8		
(d) First-aid and lifesaving equipment.....	9		
(e) Diving operations	9		
1926.606—DEFINITIONS APPLICABLE TO THIS SUBPART 9			
1926.1000—ROLLOVER PROTECTIVE STRUCTURES (ROPS) FOR MATERIAL HANDLING EQUIPMENT	9		
(a) Coverage	9		

R 408.41301 Adoption by reference of federal OSHA standard

Rule 1301. (1) The provisions of 29 C.F.R. §§1926.600 to 1926.606, 1926.1000, 1926.1001, 1926.1002, and 1926.1003, as revised December 1, 1998, are adopted by reference in these rules, except as noted in subrules (2) to (6) of this rule, and may be inspected at the Lansing office of the department of consumer and industry services. The federal construction standard may be purchased at a cost

as of the time of adoption of this rule of 75 cents by ordering page 66274 of volume 63 of the Federal Register, December 1, 1998, from the Superintendent of Documents, Washington DC 20402, or from the Occupational Safety and Health Administration Area Office, 801 South Waverly, Lansing, Michigan 48917. These sections are available at no cost from the Michigan Department of Consumer and Industry Services, 7150 Harris

Drive, P.O. Box 30643, Lansing, Michigan 48909-8143.

- (2) As of the effective date of this part, subpart K and section 1518.550, referenced in 29 C.F.R. §§1926.600, means Part 17. Electrical Installations and Part 10. Lifting and Digging Equipment, being R 408.41701a et seq. and R 408.41001a et seq., respectively.
- (3) As of the effective date of this part, section 1926.2, referenced in 29 C.F.R. §§1926.602, means Part 12. Variances, being R 408.22201 et seq. As of the effective date of this part, subparts N and W, referenced in 29 C.F.R. §§1926.602, means Part 10. Lifting and Digging Equipment and Part 13. Mobile Equipment, being R 408.41001a et seq. and R 408.41301 et seq., respectively.
- (4) As of the effective date of this part, subpart N, referenced in 29 C.F.R. §§1926.603, means Part 10. Lifting and Digging Equipment, being R 408.41001a et seq.
- (5) Paragraph (d)(1) of 29 C.F.R. §§1926.605 is excepted. Paragraph (d)(1) has been adopted by the Michigan department of consumer and industry services in R 408.40132(1) to (7).
- (6) Paragraph (d)(3) of 29 C.F.R. §§1926.605 is amended to read as follows: "Employees walking or working on the unguarded decks of barges shall be protected with United States coast guard-approved work vests or buoyant vests provided for as prescribed in R 408.40617 and R 408.40636.

1926.600—EQUIPMENT

(a) General requirements

- (1) All equipment left unattended at night, adjacent to a highway in normal use, or adjacent to construction areas where work is in progress, shall have appropriate lights or reflectors, or barricades equipped with appropriate lights or reflectors, to identify the location of the equipment.
- (2) A safety tire rack, cage, or equivalent protection shall be provided and used when inflating, mounting, or dismounting tires installed on split rims, or rims equipped with locking rings or similar devices.
- (3)
 - (i) Heavy machinery, equipment, or parts thereof, which are suspended or held aloft by use of slings, hoists, or jacks shall be substantially blocked or cribbed to prevent falling or shifting before employees are permitted to work under or between them. Bulldozer and scraper blades, end-loader buckets, dump bodies, and similar equipment, shall be either fully lowered or blocked when being repaired or when not in use. All controls shall be in a neutral position, with the motors stopped and brakes set, unless work being performed requires otherwise.
 - (ii) Whenever the equipment is parked, the parking brake shall be set. Equipment parked on inclines shall have the wheels chocked and the parking brake set.
- (4) The use, care and charging of all batteries shall conform to the requirements of Subpart K of this part.

- (5) All cab glass shall be safety glass, or equivalent, that introduces no visible distortion affecting the safe operation of any machine covered by this subpart.
- (6) All equipment covered by this subpart shall comply with the requirements of 1926.550(a)(15) when working or being moved in the vicinity of power lines or energized transmitters.
- (7) "Rolling railroad cars." Derail and/or bumper blocks shall be provided on spur railroad tracks where a rolling car could contact other cars being worked, enter a building, work or traffic area.

(b) Specific requirements

[Reserved]

1926.601—MOTOR VEHICLES

(a) Coverage

Motor vehicles as covered by this part are those vehicles that operate within an off-highway jobsite, not open to public traffic. The requirements of this section do not apply to equipment for which rules are prescribed in 1926.602.

(b) General requirements

- (1) All vehicles shall have a service brake system, an emergency brake system, and a parking brake system. These systems may use common components, and shall be maintained in operable condition.
- (2)
 - (i) Whenever visibility conditions warrant additional light, all vehicles, or combinations of vehicles, in use shall be equipped with at least two headlights and two taillights in operable condition.
 - (ii) All vehicles, or combination of vehicles, shall have brake lights in operable condition regardless of light conditions.
- (3) All vehicles shall be equipped with an adequate audible warning device at the operator's station and in an operable condition.
- (4) No employer shall use any motor vehicle equipment having an obstructed view to the rear unless:
 - (i) The vehicle has a reverse signal alarm audible above the surrounding noise level or:
 - (ii) The vehicle is backed up only when an observer signals that it is safe to do so.
- (5) All vehicles with cabs shall be equipped with windshields and powered wipers. Cracked and broken glass shall be replaced. Vehicles operating in areas or under conditions that cause fogging or frosting of the windshields shall be equipped with operable defogging or defrosting devices.
- (6) All haulage vehicles, whose pay load is loaded by means of cranes, power shovels, loaders, or similar equipment, shall have a cab shield and/or canopy adequate to protect the operator from shifting or falling materials.
- (7) Tools and material shall be secured to prevent movement when transported in the same compartment with employees.
- (8) Vehicles used to transport employees shall have seats firmly secured and adequate for the number of employees to be carried.
- (9) Seat belts and anchorages meeting the requirements of 49 CFR Part 571 (Department of

Transportation, Federal Motor Vehicle Safety Standards) shall be installed in all motor vehicles.

- (10) Trucks with dump bodies shall be equipped with positive means of support, permanently attached, and capable of being locked in position to prevent accidental lowering of the body while maintenance or inspection work is being done.
- (11) Operating levers controlling hoisting or dumping devices on haulage bodies shall be equipped with a latch or other device which will prevent accidental starting or tripping of the mechanism.
- (12) Trip handles for tailgates of dump trucks shall be so arranged that, in dumping, the operator will be in the clear.
- (13)
 - (i) All rubber-tired motor vehicle equipment manufactured on or after May 1, 1972, shall be equipped with fenders. All rubber-tired motor vehicle equipment manufactured before May 1, 1972, shall be equipped with fenders not later than May 1, 1973.
 - (ii) Mud flaps may be used in lieu of fenders whenever motor vehicle equipment is not designed for fenders.
- (14) All vehicles in use shall be checked at the beginning of each shift to assure that the following parts, equipment, and accessories are in safe operating condition and free of apparent damage that could cause failure while in use: service brakes, including trailer brake connections; parking system (hand brake); emergency stopping system (brakes); tires; horn; steering mechanism; coupling devices; seat belts; operating controls; and safety devices. All defects shall be corrected before the vehicle is placed in service. These requirements also apply to equipment such as lights, reflectors, windshield wipers, defrosters, fire extinguishers, etc., where such equipment is necessary.

1926.602—MATERIAL HANDLING EQUIPMENT

(a) Earthmoving equipment; general

- (1) These rules apply to the following types of earthmoving equipment: scrapers, loaders, crawler or wheel tractors, bulldozers, off-highway trucks, graders, agricultural and industrial tractors, and similar equipment. The promulgation of specific rules for compactors and rubber-tired "skid-steer" equipment is reserved pending consideration of standards currently being developed.
- (2)
 - (i) Seat belts shall be provided on all equipment covered by this section and shall meet the requirements of the Society of Automotive Engineers, J386-1969, Seat Belts for Construction Equipment. Seat belts for agricultural and light industrial tractors shall meet the seat belt requirements of Society of Automotive Engineers J333a-1970, Operator Protection for Agricultural and Light Industrial Tractors.
 - (ii) Seat belts need not be provided for equipment which is designed only for stand-up operation.
 - (iii) Seat belts need not be provided for equipment which does not have roll-over protective

structure (ROPS) or adequate canopy protection.

- (3) Access roadways and grades.
 - (i) No employer shall move or cause to be moved construction equipment or vehicles upon any access roadway or grade unless the access roadway or grade is constructed and maintained to accommodate safely the movement of the equipment and vehicles involved.
 - (ii) Every emergency access ramp and berm used by an employer shall be constructed to restrain and control runaway vehicles.
- (4) Brakes. All earthmoving equipment mentioned in this 1926.602(a) shall have a service braking system capable of stopping and holding the equipment fully loaded, as specified in Society of Automotive Engineers SAE-J237, Loader Dozer-1971, J236, Graders-1971, and J319b, Scrapers-1971. Brake systems for self-propelled rubber-tired off-highway equipment manufactured after January 1, 1972 shall meet the applicable minimum performance criteria set forth in the following Society of Automotive Engineers Recommended Practices:

Self-Propelled Scrapers	SAE J319b-1971
Self-Propelled Graders	SAE J236-1971
Trucks and Wagons	SAE J166-1971
Front End Loaders and Dozers	SAE J237-1971

- (5) Fenders. Pneumatic-tired earth-moving haulage equipment (trucks, scrapers, tractors, and trailing units) whose maximum speed exceeds 15 miles per hour, shall be equipped with fenders on all wheels to meet the requirements of Society of Automotive Engineers SAE J321a-1970, Fenders for Pneumatic-Tired Earthmoving Haulage Equipment. An employer may, of course, at any time seek to show under 1926.2, that the uncovered wheels present no hazard to personnel from flying materials.
- (6) Rollover protective structures (ROPS). See Subpart W of this part for requirements for rollover protective structures and overhead protection.
- (7) Rollover protective structures for off-highway trucks. The promulgation of standards for rollover protective structures for off-highway trucks is reserved pending further study and development.
- (8) Specific effective dates-brakes and fenders.
 - (i) Equipment mentioned in paragraph (a)(4) and (5) of this section, and manufactured after January 1, 1972, which is used by any employer after that date, shall comply with the applicable rules prescribed therein concerning brakes and fenders. Equipment mentioned in paragraphs (a) (4) and (5) of this section, and manufactured before January 1, 1972, which is used by any employer after that date, shall meet the applicable rules prescribed herein not later than June 30, 1973. It should be noted that, as permitted under 1926.2, employers may request variations from the applicable brakes and fender standards required by this subpart. Employers wishing to seek variations from the applicable brakes and fenders rules may submit any requests for variations after the publication of this document in the Federal Register. Any statements intending to meet the

requirements of 1926.2(b)(4), should specify how the variation would protect the safety of the employees by providing for any compensating restrictions on the operation of equipment.

- (ii) Notwithstanding the provisions of paragraphs (a)(5) and (a)(8)(i) of this section, the requirement that fenders be installed on pneumatic-tired earthmoving haulage equipment, is suspended pending reconsideration of the requirement.

(9) Audible alarms.

- (i) All bidirectional machines, such as rollers, compactors, front-end loaders, bulldozers, and similar equipment, shall be equipped with a horn, distinguishable from the surrounding noise level, which shall be operated as needed when the machine is moving in either direction. The horn shall be maintained in an operative condition.
- (ii) No employer shall permit earthmoving or compacting equipment which has an obstructed view to the rear to be used in reverse gear unless the equipment has in operation a reverse signal alarm distinguishable from the surrounding noise level or an employee signals that it is safe to do so.

- (10) Scissor points.** Scissor points on all front-end loaders, which constitute a hazard to the operator during normal operation, shall be guarded.

(b) Excavating and other equipment

- (1)** Tractors covered in paragraph (a) of this section shall have seat belts as required for the operators when seated in the normal seating arrangement for tractor operation, even though back-hoes, breakers, or other similar attachments are used on these machines for excavating or other work.
- (2)** For the purposes of this subpart and of Subpart N of this part, the nomenclatures and descriptions for measurement of dimensions of machinery and attachments shall be as described in Society of Automotive Engineers 1970 Handbook, pages 1088 through 1103.
- (3)** The safety requirements, ratios, or limitations applicable to machines or attachment usage covered in Power Crane and Shovel Associations Standards No. 1 and No. 2 of 1968, and No. 3 of 1969, shall be complied with, and shall apply to cranes, machines, and attachments under this part.

(c) Lifting and hauling equipment

(other than equipment covered under Subpart N of this part)

- (1)** Industrial trucks shall meet the requirements of §§1926.600 and the following:
 - (i) Lift trucks, stackers, etc., shall have the rated capacity clearly posted on the vehicle so as to be clearly visible to the operator. When auxiliary removable counterweights are provided by the manufacturer, corresponding alternate rated capacities also shall be clearly shown on the vehicle. These ratings shall not be exceeded.
 - (ii) No modifications or additions which affect the capacity or safe operation of the equipment shall be made without the manufacturer's

written approval. If such modifications or changes are made, the capacity, operation, and maintenance instruction plates, tags, or decals shall be changed accordingly. In no case shall the original safety factor of the equipment be reduced.

- (iii) If a load is lifted by two or more trucks working in unison, the proportion of the total load carried by any one truck shall not exceed its capacity.
- (iv) Steering or spinner knobs shall not be attached to the steering wheel unless the steering mechanism is of a type that prevents road reactions from causing the steering handwheel to spin. The steering knob shall be mounted within the periphery of the wheel.
- (v) All high lift rider industrial trucks shall be equipped with overhead guards which meet the configuration and structural requirements as defined in paragraph 421 of American National Standards Institute B56.1-1993, Low Lift and High Lift Trucks.
- (vi) All industrial trucks in use shall meet the applicable requirements of design, construction, stability, inspection, testing, maintenance, and operation, as defined in American National Standards Institute B56.1-1993, Low Lift and High Lift Trucks.
- (vii) Unauthorized personnel shall not be permitted to ride on powered industrial trucks. A safe place to ride shall be provided where riding of trucks is authorized.
- (viii) Whenever a truck is equipped with vertical only, or vertical and horizontal controls elevatable with the lifting carriage or forks for lifting personnel, the following additional precautions shall be taken for the protection of personnel being elevated.
 - (A) Use of a safety platform firmly secured to the lifting carriage and/or forks.
 - (B) Means shall be provided whereby personnel on the platform can shut off power to the truck.
 - (C) Such protection from falling objects as indicated necessary by the operating conditions shall be provided.

(d) Powered industrial truck operator training

Note: The requirements applicable to construction work under this paragraph are identical to those set forth at §§1910.178(l).

1910.178(l) Operator training. Safe operation.

- (i) The employer shall ensure that each powered industrial truck operator is competent to operate a powered industrial truck safely, as demonstrated by the successful completion of the training and evaluation specified in this paragraph.
- (ii) Prior to permitting an employee to operate a powered industrial truck (except for training purposes), the employer shall ensure that each operator has successfully completed the training required by this paragraph (l), except as permitted by paragraph (l)(5).
- (2) Training program implementation.**
 - (i) Trainees may operate a powered industrial truck only:

- (A) Under the direct supervision of persons who have the knowledge, training, and experience to train operators and evaluate their competence; and
- (B) Where such operation does not endanger the trainee or other employees.
- (ii) Training shall consist of a combination of formal instruction (e.g., lecture, discussion, interactive computer learning, video tape, written material), practical training (demonstrations performed by the trainer and practical exercises performed by the trainee), and evaluation of the operator's performance in the workplace.
- (iii) All operator training and evaluation shall be conducted by persons who have the knowledge, training, and experience to train powered industrial truck operators and evaluate their competence.
- (3) Training program content.** Powered industrial truck operators shall receive initial training in the following topics, except in topics which the employer can demonstrate are not applicable to safe operation of the truck in the employer's workplace.
 - (i) Truck-related topics:
 - (A) Operating instructions, warnings, and precautions for the types of truck the operator will be authorized to operate;
 - (B) Differences between the truck and the automobile;
 - (C) Truck controls and instrumentation: where they are located, what they do, and how they work;
 - (D) Engine or motor operation;
 - (E) Steering and maneuvering;
 - (F) Visibility (including restrictions due to loading);
 - (G) Fork and attachment adaptation, operation, and use limitations;
 - (H) Vehicle capacity;
 - (I) Vehicle stability;
 - (J) Any vehicle inspection and maintenance that the operator will be required to perform;
 - (K) Refueling and/or charging and recharging of batteries;
 - (L) Operating limitations;
 - (M) Any other operating instructions, warnings, or precautions listed in the operator's manual for the types of vehicle that the employee is being trained to operate.
 - (ii) Workplace-related topics:
 - (A) Surface conditions where the vehicle will be operated;
 - (B) Composition of loads to be carried and load stability;
 - (C) Load manipulation, stacking, and unstacking;
 - (D) Pedestrian traffic in areas where the vehicle will be operated;
 - (E) Narrow aisles and other restricted places where the vehicle will be operated;
 - (F) Hazardous (classified) locations where the vehicle will be operated;
 - (G) Ramps and other sloped surfaces that could affect the vehicle's stability;

- (H) Closed environments and other areas where insufficient ventilation or poor vehicle maintenance could cause a buildup of carbon monoxide or diesel exhaust;
- (I) Other unique or potentially hazardous environmental conditions in the workplace that could affect safe operation.
- (iii) The requirements of this section.
- (4) Refresher training and evaluation.**
 - (i) Refresher training, including an evaluation of the effectiveness of that training, shall be conducted as required by paragraph (I)(4)(ii) to ensure that the operator has the knowledge and skills needed to operate the powered industrial truck safely.
 - (ii) Refresher training in relevant topics shall be provided to the operator when:
 - (A) The operator has been observed to operate the vehicle in an unsafe manner;
 - (B) The operator has been involved in an accident or near-miss incident;
 - (C) The operator has received an evaluation that reveals that the operator is not operating the truck safely;
 - (D) The operator is assigned to drive a different type of truck; or
 - (E) A condition in the workplace changes in a manner that could affect safe operation of the truck.
 - (iii) An evaluation of each powered industrial truck operator's performance shall be conducted at least once every three years.
- (5) Avoidance of duplicative training.** If an operator has previously received training in a topic specified in paragraph (I)(3) of this section, and such training is appropriate to the truck and working conditions encountered, additional training in that topic is not required if the operator has been evaluated and found competent to operate the truck safely.
- (6) Certification.** The employer shall certify that each operator has been trained and evaluated as required by this paragraph (I). The certification shall include the name of the operator, the date of the training, the date of the evaluation, and the identity of the person(s) performing the training or evaluation.
- (7) Dates.** The employer shall ensure that operators of powered industrial trucks are trained, as appropriate, by the dates shown in the following table.

If the employee was hired:	The initial training and evaluation of that employee must be completed:
Before July 30, 2000	By July 30, 2000
After July 30, 2000	Before the employee is assigned to operate a powered industrial truck.

Note: Appendix A—Stability of Powered Industrial Trucks (non-mandatory) maybe referred to—to enhance training. It appears at the end of the standard—Appendix A.

- (8) Appendix A** to this section provides non-mandatory guidance to assist employers in implementing this paragraph (I). This appendix does not add to, alter, or reduce the requirements of this section.

Appendix A--Stability of Powered Industrial Trucks
(Non-mandatory - may be referred to — to enhance training)

A-1. Definitions.

The following definitions help to explain the principle of stability:

Center of gravity is the point on an object at which all of the object's weight is concentrated. For symmetrical loads, the center of gravity is at the middle of the load.

Counterweight is the weight that is built into the truck's basic structure and is used to offset the load's weight and to maximize the vehicle's resistance to tipping over.

Fulcrum is the truck's axis of rotation when it tips over.

Grade is the slope of a surface, which is usually measured as the number of feet of rise or fall over a hundred foot horizontal distance (the slope is expressed as a percent).

Lateral stability is a truck's resistance to overturning sideways.

Line of action is an imaginary vertical line through an object's center of gravity.

Load center is the horizontal distance from the load's edge (or the fork's or other attachment's vertical face) to the line of action through the load's center of gravity.

Longitudinal stability is the truck's resistance to overturning forward or rearward.

Moment is the product of the object's weight times the distance from a fixed point (usually the fulcrum). In the case of a powered industrial truck, the distance is measured from the point at which the truck will tip over to the object's line of action. The distance is always measured perpendicular to the line of action.

Track is the distance between the wheels on the same axle of the truck.

Wheelbase is the distance between the centerline of the vehicle's front and rear wheels.

A-2. General

A-2.1. Determining the stability of a powered industrial truck is simple once a few basic principles are understood. There are many factors that contribute to a vehicle's stability: the vehicle's wheelbase, track, and height; the load's weight distribution; and the vehicle's counterweight location (if the vehicle is so equipped).

A-2.2. The "stability triangle," used in most stability discussions, demonstrates stability simply.

A-3. Basic Principles

A-3.1. Whether an object is stable depends on the object's moment at one end of a system being greater than, equal to, or smaller than the object's moment at the system's other end. This principle can be seen in the way a see-saw or teeter-totter works: that is, if the product of the load and distance from the fulcrum (moment) is equal to the moment at the device's other end, the device is balanced and it will not move. However, if there is a greater moment at one end of the device, the device will try to move downward at the end with the greater moment.

A-3.2. The longitudinal stability of a counterbalanced powered industrial truck depends on the vehicle's moment and the load's moment. In other words, if the mathematic product of the load moment (the distance from the front wheels, the approximate point at which the vehicle would tip forward) to the load's center of gravity times the load's weight is less than the vehicle's moment, the system is balanced and will not tip forward. However, if the load's moment is greater than the vehicle's moment, the greater load-moment will force the truck to tip forward.

A-4. The Stability Triangle

A-4.1. Almost all counterbalanced powered industrial trucks have a three-point suspension system, that is, the vehicle is supported at three points. This is true even if the vehicle has four wheels. The truck's steer axle is attached to the truck by a pivot pin in the axle's center. When the points are connected with imaginary lines, this three-point support forms a triangle called the stability triangle. Figure 1 depicts the stability triangle.

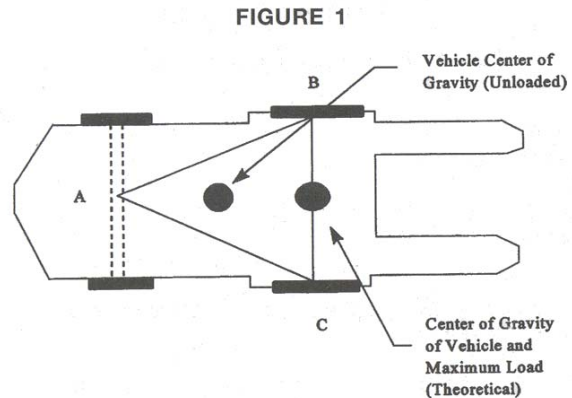

Notes:

1. When the vehicle is loaded, the combined center of gravity (CG) shifts toward line B-C. Theoretically the maximum load will result in the CG at the line B-C. In actual practice, the combined CG should never be at line B-C.

2. The addition of additional counterweight will cause the truck CG to shift toward point A and result in a truck that is less stable laterally.

A-4.2. When the vehicle's line of action, or load center, falls within the stability triangle, the vehicle is stable and will not tip over. However, when the vehicle's line of action or the vehicle/ load combination falls outside the stability triangle, the vehicle is unstable and may tip over. (See Figure 2.)

FIGURE 2

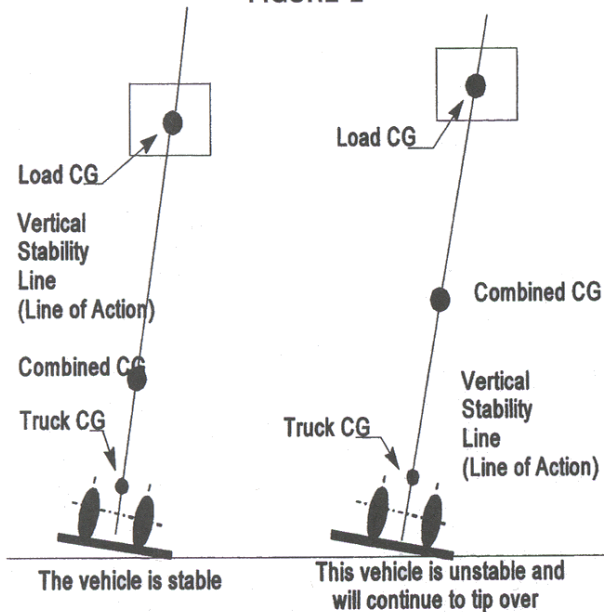

A-5. Longitudinal Stability.

A-5.1. The axis of rotation when a truck tips forward is the front wheels' points of contact with the pavement. When a powered industrial truck tips forward, the truck will rotate about this line. When a truck is stable, the vehicle-moment must exceed the load-moment. As long as the vehicle-moment is equal to or exceeds the load-moment, the vehicle will not tip over. On the other hand, if the load moment slightly exceeds the vehicle-moment, the truck will begin to tip forward, thereby causing the rear to lose contact with the floor or ground and resulting in loss of steering control. If the load-moment greatly exceeds the vehicle moment, the truck will tip forward.

A-5.2. To determine the maximum safe load-moment, the truck manufacturer normally rates the truck at a maximum load at a given distance from the front face of the forks. The specified distance from the front face of the forks to the line of action of the load is commonly called the load center. Because larger trucks normally handle loads that are physically larger, these vehicles have greater load centers. Trucks with a capacity of 30,000 pounds or less are normally rated at a given load weight at a 24-inch load center. Trucks with a capacity greater than 30,000 pounds are normally rated at a given load weight at a 36- or 48-inch load center. To safely operate the vehicle, the operator should always check the data plate to determine the maximum allowable weight at the rated load center.

A-5.3. Although the true load-moment distance is measured from the front wheels, this distance is greater than the distance from the front face of the forks. Calculating the maximum allowable load-moment using the load-center distance always provides a lower load-moment than the truck was designed to handle. When handling unusual loads, such as those that are larger than 48 inches long (the center of gravity is greater than 24 inches) or that have an offset center of gravity, etc., a maximum allowable load-moment should be calculated and used to determine whether a load can be safely handled. For example, if an operator is operating a 3000 pound capacity truck (with a 24-inch load center), the maximum allowable load-moment is 72,000 inch-pounds (3,000 times 24). If a load is 60 inches long (30-inch load center), then the maximum that this load can weigh is 2,400 pounds (72,000 divided by 30).

A-6. Lateral Stability

A-6.1. The vehicle's lateral stability is determined by the line of action's position (a vertical line that passes through the combined vehicle's and load's center of gravity) relative to the stability triangle. When the vehicle is not loaded, the truck's center of gravity location is the only factor to be considered in determining the truck's stability. As long as the line of action of the combined vehicle's and load's center of gravity falls within the stability triangle, the truck is stable and will not tip over. However, if the line of action falls outside the stability triangle, the truck is not stable and may tip over. Refer to Figure 2.

A-6.2. Factors that affect the vehicle's lateral stability include the load's placement on the truck, the height of the load above the surface on which the vehicle is operating, and the vehicle's degree of lean.

A-7. Dynamic Stability

A-7.1. Up to this point, the stability of a powered industrial truck has been discussed without considering the dynamic forces that result when the vehicle and load are put into motion. The weight's transfer and the resultant shift in the center of gravity due to the dynamic forces created when the machine is moving, braking, cornering, lifting, tilting, and lowering loads, etc., are important stability considerations.

A-7.2. When determining whether a load can be safely handled, the operator should exercise extra caution when handling loads that cause the vehicle to approach its maximum design characteristics. For example, if an operator must handle a maximum load, the load should be carried at the lowest position possible, the truck should be accelerated slowly and evenly, and the forks should be tilted forward cautiously. However, no precise rules can be formulated to cover all of these eventualities.

1926.603—PILE DRIVING EQUIPMENT

(a) General requirements

- (1) Boilers and piping systems which are a part of, or used with, pile driving equipment shall meet the applicable requirements of the American Society of Mechanical Engineers, Power Boilers (section I).
- (2) All pressure vessels which are a part of, or used with, pile driving equipment shall meet the applicable requirements of the American Society of Mechanical Engineers, Pressure Vessels (section VIII).
- (3) Overhead protection, which will not obscure the vision of the operator and which meets the requirements of Subpart N of this part, shall be provided. Protection shall be the equivalent of 2-inch planking or other solid material of equivalent strength.
- (4) Stop blocks shall be provided for the leads to prevent the hammer from being raised against the head block.
- (5) A blocking device, capable of safely supporting the weight of the hammer, shall be provided for placement in the leads under the hammer at all times while employees are working under the hammer.
- (6) Guards shall be provided across the top of the head block to prevent the cable from jumping out of the sheaves.

- (7) When the leads must be inclined in the driving of batter piles, provisions shall be made to stabilize the leads.
- (8) Fixed leads shall be provided with ladder, and adequate rings, or similar attachment points, so that the loft worker may engage his safety belt lanyard to the leads. If the leads are provided with loft platforms(s), such platform(s) shall be protected by standard guardrails.
- (9) Steam hose leading to a steam hammer or jet pipe shall be securely attached to the hammer with an adequate length of at least 1/4-inch diameter chain or cable to prevent whipping in the event the joint at the hammer is broken. Air hammer hoses shall be provided with the same protection as required for steam lines.
- (10) Safety chains, or equivalent means, shall be provided for each hose connection to prevent the line from thrashing around in case the coupling becomes disconnected.
- (11) Steam line controls shall consist of two shutoff valves, one of which shall be a quick-acting lever type within easy reach of the hammer operator.
- (12) Guys, outriggers, thrustouts, or counterbalances shall be provided as necessary to maintain stability of pile driver rigs.

(b) Pile driving from barges and floats

Barges or floats supporting pile driving operations shall meet the applicable requirements of 1926.605.

(c) Pile driving equipment

- (1) Engineers and winchmen shall accept signals only from the designated signalmen.
- (2) All employees shall be kept clear when piling is being hoisted into the leads.
- (3) When piles are being driven in an excavated pit, the walls of the pit shall be sloped to the angle of repose or sheet-piled and braced.
- (4) When steel tube piles are being "blown out", employees shall be kept well beyond the range of falling materials.
- (5) When it is necessary to cut off the tops of driven piles, pile driving operations shall be suspended except where the cutting operations are located at least twice the length of the longest pile from the driver.
- (6) When driving jacked piles, all access pits shall be provided with ladders and bulkheaded curbs to prevent material from falling into the pit.

1926.604—SITE CLEARING

(a) General requirements

- (1) Employees engaged in site clearing shall be protected from hazards of irritant and toxic plants and suitably instructed in the first aid treatment available.
- (2) All equipment used in site clearing operations shall be equipped with rollover guards meeting the requirements of this subpart. In addition, rider-operated equipment shall be equipped with an overhead and rear canopy guard meeting the following requirements:
 - (i) The overhead covering on this canopy structure shall be of not less than 1/8-inch

steel plate or 1/4-inch woven wire mesh with openings no greater than 1 inch, or equivalent.

- (ii) The opening in the rear of the canopy structure shall be covered with not less than 1/4-inch woven wire mesh with openings no greater than 1 inch.

(b) Specific requirements

[Reserved]

1926.605—MARINE OPERATIONS AND EQUIPMENT

(a) Material handling operations

- (1) Operations fitting the definition of "material handling" shall be performed in conformance with applicable requirements of Part 1918, "Safety and Health Regulations for Longshoring" of this chapter. The term "longshoring operations" means the loading, unloading, moving, or handling of construction materials, equipment and supplies, etc. into, in, on, or out of any vessel from a fixed structure or shore-to-vessel, vessel-to-shore or fixed structure or vessel-to-vessel.

(b) Access to barges

- (1) Ramps for access of vehicles to or between barges shall be of adequate strength, provided with side boards, well maintained, and properly secured.
- (2) Unless employees can step safely to or from the wharf, float, barge, or river towboat, either a ramp, meeting the requirements of paragraph (b)(1) of this section, or a safe walkway, shall be provided.
- (3) Jacob's ladders shall be of the double rung or flat tread type. They shall be well maintained and properly secured.
- (4) A Jacob's ladder shall either hang without slack from its lashings or be pulled up entirely.
- (5) When the upper end of the means of access rests on or is flush with the top of the bulwark, substantial steps properly secured and equipped with at least one substantial hand rail approximately 33 inches in height, shall be provided between the top of the bulwark and the deck.
- (6) Obstructions shall not be laid on or across the gangway.
- (7) The means of access shall be adequately illuminated for its full length.
- (8) Unless the structure makes it impossible, the means of access shall be so located that the load will not pass over employees.

(c) Working surfaces of barges

- (1) Employees shall not be permitted to walk along the sides of covered lighters or barges with coamings more than 5 feet high, unless there is a 3-foot clear walkway, or a grab rail, or a taut handline is provided.
- (2) Decks and other working surfaces shall be maintained in a safe condition.
- (3) Employees shall not be permitted to pass fore and aft, over, or around deckloads, unless there is a safe passage.
- (4) Employees shall not be permitted to walk over deckloads from rail to coaming unless there is a safe passage. If it is necessary to stand at the outboard or inboard edge of the deckload where

less than 24 inches of bulwark, rail, coaming, or other protection exists, all employees shall be provided with a suitable means of protection against falling from the deckload.

(d) First-aid and lifesaving equipment

- (2) The employer shall ensure that there is in the vicinity of each barge in use at least one U.S. Coast Guard-approved 30-inch lifering with not less than 90 feet of line attached, and at least one portable or permanent ladder which will reach the top of the apron to the surface of the water. If the above equipment is not available at the pier, the employer shall furnish it during the time that he is working the barge.
- (3) Employees walking or working on the unguarded decks of barges shall be protected with U.S. Coast Guard-approved work vests or buoyant vests.

(e) Diving operations

[Reserved].

1926.606—DEFINITIONS APPLICABLE TO THIS SUBPART

- (a) **“Apron”** - The area along the waterfront edge of the pier or wharf.
- (b) **“Bulwark”** - The side of a ship above the upper deck.
- (c) **“Coaming”** - The raised frame, as around a hatchway in the deck, to keep out water.
- (d) **“Jacob’s ladder”** - A marine ladder of rope or chain with wooden or metal rungs.
- (e) **“Rail”** for the purpose of 1926.605, means a light structure serving as a guard at the outer edge of a ship’s deck.

1926.1000—ROLLOVER PROTECTIVE STRUCTURES (ROPS) FOR MATERIAL HANDLING EQUIPMENT

(a) Coverage

- (1) This section applies to the following types of material handling equipment: To all rubber-tired, self-propelled scrapers, rubber-tired front-end loaders, rubber-tired dozers, wheel-type agricultural and industrial tractors, crawler tractors, crawler-type loaders, and motor graders, with or without attachments, that are used in construction work. This requirement does not apply to sideboom pipe laying tractors.
- (2) The promulgation of specific standards for rollover protective structures for compactors and rubber-tired skid-steer equipment is reserved pending consideration of standards currently being developed.

(b) Equipment manufactured on or after September 1, 1972

Material handling machinery described in paragraph (a) of this section and manufactured on or after September 1, 1972, shall be equipped with rollover protective structures which meet the minimum performance standards prescribed in 1926.1001 and 1926.1002, as applicable.

(c) Equipment manufactured before September 1, 1972

- (1) All material handling equipment described in paragraph (a) of this section and manufactured or placed in service (owned or operated by the employer) prior to September 1, 1972, shall be fitted with rollover protective structures no later than the dates listed below:
 - (i) Machines manufactured on or after January 1, 1972, shall be fitted no later than April 1, 1973.
 - (ii) Machines manufactured between July 1, 1971, and December 31, 1971, shall be fitted no later than July 1, 1973.
 - (iii) Machines manufactured between July 1, 1970, and June 30, 1971, shall be fitted no later than January 1, 1974.
 - (iv) Machines manufactured between July 1, 1969, and June 30, 1970, shall be fitted no later than July 1, 1974.
 - (v) Machines manufactured before July 1, 1969: Reserved pending further study, development, and review.

- (2) Rollover protective structures and supporting attachment shall meet the minimum performance criteria detailed in 1926.1001 and 1926.1002, as applicable or shall be designed, fabricated, and installed in a manner which will support, based on the ultimate strength of the metal, at least two times the weight of the prime mover applied at the point of impact.

- (i) The design objective shall be to minimize the likelihood of a complete overturn and thereby minimize the possibility of the operator being crushed as a result of a rollover or upset.
- (ii) The design shall provide a vertical clearance of at least 52 inches from the work deck to the ROPS at the point of ingress or egress.

(d) Remounting

ROPS removed for any reason, shall be remounted with equal quality, or better, bolts or welding as required for the original mounting.

(e) Labeling

Each ROPS shall have the following information permanently affixed to the structure:

- (1) Manufacturer or fabricator’s name and address;
- (2) ROPS model number, if any;
- (3) Machine make, model, or series number that the structure is designed to fit.

(f) Machines meeting certain existing governmental requirements

Any machine in use, equipped with rollover protective structures, shall be deemed in compliance with this section if it meets the rollover protective structure requirements of the State of California, the U.S. Army Corps of Engineers, or the Bureau of Reclamation of the U.S. Department of the Interior in effect on April 5, 1972. The requirements in effect are:

- (1) State of California: Construction Safety Orders, issued by the Department of Industrial Relations pursuant to Division 5, Labor Code, 6312, State of California.
- (2) U.S. Army Corps of Engineers: General Safety Requirements, EM-385-1-1 (March 1967).
- (3) Bureau of Reclamation, U.S. Department of the Interior: Safety and Health Regulations for Construction. Part II (September 1971).

1926.1001—MINIMUM PERFORMANCE CRITERIA FOR ROLLOVER PROTECTIVE STRUCTURES FOR DESIGNATED SCRAPERS, LOADERS, DOZERS, GRADERS, AND CRAWLER TRACTORS

(a) General

This section prescribes minimum performance criteria for rollover protective structures (ROPS) for rubber-tired self-propelled scrapers; rubber-tired front-end loaders and rubber-tired dozers; crawler tractors, and crawler-type loaders, and motor graders. The vehicle and ROPS as a system shall have the structural characteristics prescribed in paragraph (f) of this section for each type of machine described in this paragraph.

(b) The static laboratory test

prescribed herein will determine the adequacy of the structures used to protect the operator under the following conditions:

- (1) For rubber-tired self-propelled scrapers, rubber-tired front-end loaders, and rubber-tired dozers: Operating between 0 and 10 miles per hour over hard clay where rollover would be limited to a maximum roll angle of 360 deg. down a slope of 30 deg. maximum.
- (2) For motor graders: Operating between 0 and 10 miles per hour over hard clay where rollover would be limited to 360 deg. down a slope of 30 deg. maximum.
- (3) For crawler tractors and crawler-type loaders: Operating between 0 and 10 miles per hour over hard clay where rollover would be limited to a maximum roll angle of 360 deg down a slope of 45 deg.

(c) Facilities and apparatus

- (1) The following material is necessary:
 - (i) Material, equipment, and tiedown means adequate to insure that the ROPS and its vehicle frame absorb the applied energy.
 - (ii) Equipment necessary to measure and apply loads to the ROPS. Adequate means to measure deflections and lengths should also be provided.
 - (iii) Recommended, but not mandatory, types of test setups are illustrated in Figure W-1 for all types of equipment to which this section applies; and in Figure W-2 for rubber-tired self-propelled scrapers; Figure W-3 for rubber-tired front-end loaders, rubber-tired dozers, and motor graders; and Figure W-4 for crawler tractors and crawler-type loaders.
- (2) Table W-1 contains a listing of the required apparatus for all types of equipment described in paragraph of this section.

TABLE W-1

Means to measure	Accuracy
Deflection of ROPS, inches	+ or - 5 percent of deflection measured
Vehicle weight, pounds	+ or - 5 percent of the weight measured
Force applied to frame, pound	+ or - 5 percent of force measured
Dimensions of critical zone, inches	+ or - 0.5 in

(d) Vehicle condition

The ROPS to be tested must be attached to the vehicle structure in the same manner as it will be attached during vehicle use. A totally assembled vehicle is not required. However, the vehicle structure and frame which support the ROPS must represent the actual vehicle installation. All normally detachable windows, panels, or nonstructural fittings shall be removed so that they do not contribute to the strength of the ROPS.

(e) Test procedure

The test procedure shall include the following, in the sequence indicated:

- (1) Energy absorbing capabilities of ROPS shall be verified when loaded laterally by incrementally applying a distributed load to the longitudinal outside top member of the ROPS, as shown in Figure W-1, W-2, or W-3, as applicable. The distributed load must be applied so as to result in approximately uniform deflection of the ROPS. The load increments should correspond with approximately 0.5 in. ROPS deflection increment in the direction of the load application, measured at the ROPS top edge. Should the operator's seat be offcenter, the load shall be applied on the offcenter side. For each applied load increment, the total load (lb.) versus corresponding deflection (in.) shall be plotted, and the area under the load-deflection curve shall be calculated. This area is equal to the energy (in.-lb.) absorbed by the ROPS. For a typical load-deflection curve and calculation method, see Figure W-5.

FIGURE W-1

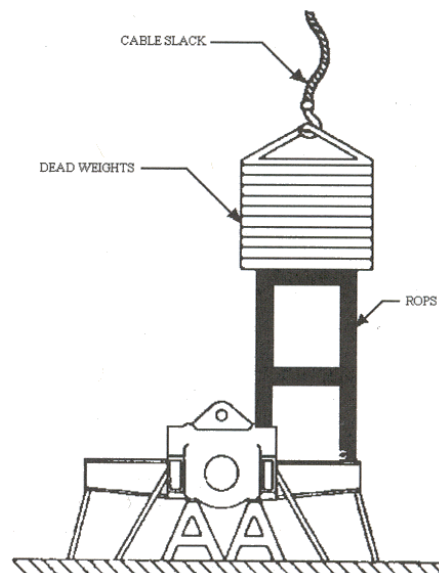

FIGURE W-1 - Vertical loading setup for all types of equipment described in 1518.1001(a).

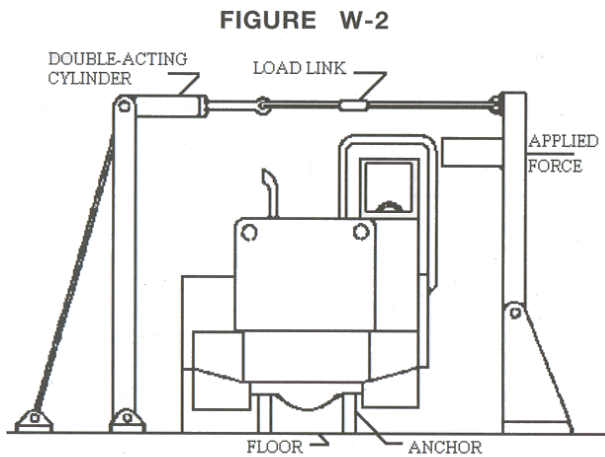

FIGURE W-2 - Test setup for rubber-tired self-propelled scrapers.

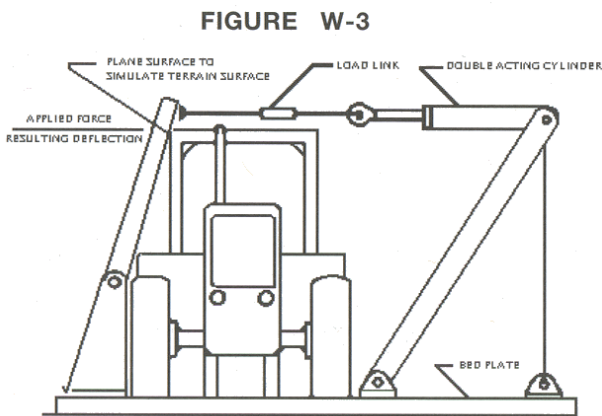

FIGURE W-3 -- Test setup for rubber-tired front-end loaders, rubber-tired dozers, and motor graders.

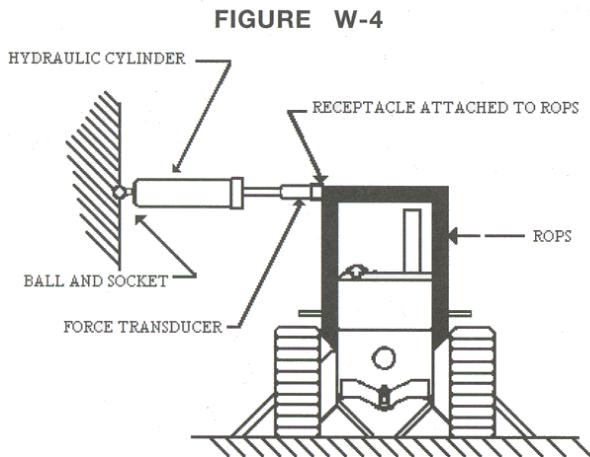
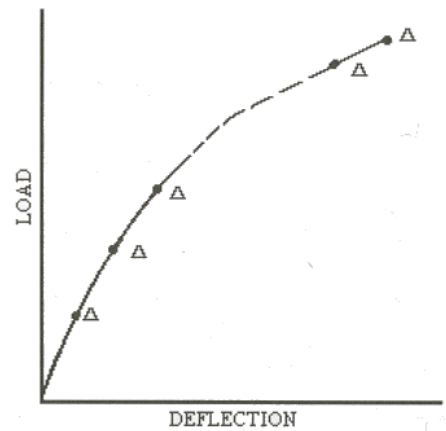

FIGURE W-4 -- Side-loading setup for crawler tractors and crawler loaders.

Incremental loading shall be continued until the ROPS has absorbed the amount of energy and the minimum applied load specified under paragraph (f) of this section has been reached or surpassed.

- (2) To cover the possibility of the vehicle coming to rest on its top, the support capability shall be verified by applying a distributed vertical load to the top of the ROPS so as to result in approximately uniform deflection (see Figure W-1). The load magnitude is specified in paragraph (f)(2)(iii) of this section.
- (3) The low temperature impact strength of the material used in the ROPS shall be verified by suitable material tests or material certification (see paragraph (f)(2)(iv) of this section).

FIGURE W-5



Δ- TOTAL DEFLECTION
F - FORCE APPLIED

$$\text{AREA} = \frac{\Delta_1 F_1}{2} + (\Delta_2 - \Delta_1) \frac{F_1 + F_2}{2} + (\Delta_3 - \Delta_2) \frac{F_2 + F_3}{2} + \dots + (\Delta_N - \Delta_{N-1}) \frac{F_{N-1} + F_N}{2}$$

Figure W-5 - Determination of energy area under force deflection curve for all types of ROPS equipment defined in 1926.1101.

(f) Performance requirements

- (1) General performance requirements.
 - (i) No repairs or straightening of any member shall be carried out between each prescribed test.
 - (ii) During each test, no part of the ROPS shall enter the critical zone as detailed in SAE J397 (1969). Deformation of the ROPS shall not allow the plane of the ground to enter this zone.
- (2) Specific performance requirements.
 - (i) The energy requirement for purposes of meeting the requirements of paragraph (e)(1) of this section is to be determined by referring to the plot of the energy versus weight of vehicle (see Figure W-6 for rubber-tired self-propelled scrapers; Figure W-7 for rubber-tired front-end loaders and rubber-tired dozers; Figure W-8 for crawler tractors and crawler-type loaders; and Figure W-9 for motor graders). For purposes of this section, force and weight are measured as pounds (lb.); energy (U) is measured as inch-pounds.

FIGURE W-6

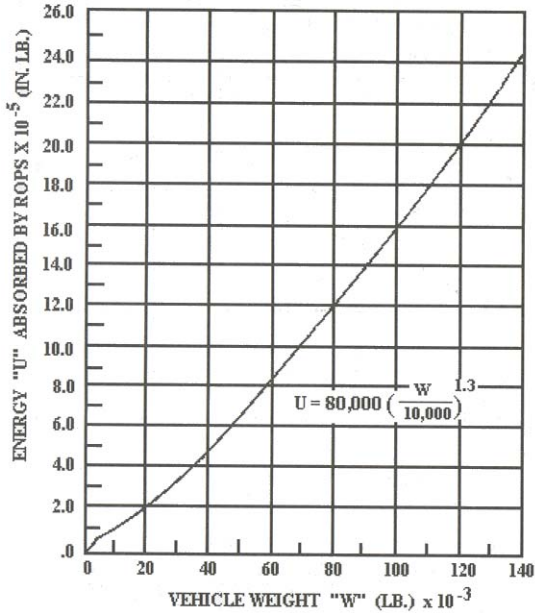

FIGURE W-6-ENERGY ASORBED VERSUS VEHICLE WEIGHT

- (ii) The applied load must attain at least a value which is determined by multiplying the vehicle weight by the corresponding factor shown in Figure W-10 for rubber-tired self-propelled scrapers; in Figure W-11 for rubber-tired front-end loaders and rubber-tired dozers; in Figure W-12 for crawler tractors and crawler-type loaders; and in Figure W-13 for motor graders.
- (iii) The load magnitude for purposes of compliance with paragraph (e)(2) of this section is equal to the vehicle weight. The test of load magnitude shall only be made after the requirements of paragraph (f)(2)(i) of this section are met.

FIGURE W-7

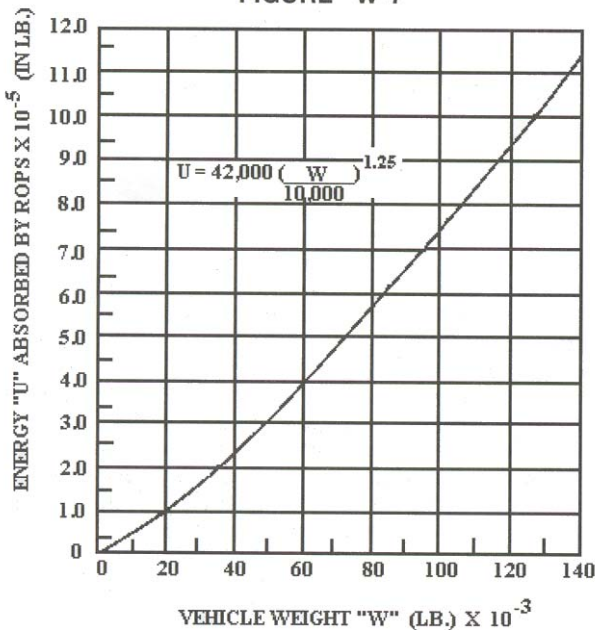

FIGURE W-7 - ENERGY ABSORBED VERSUS VEHICLE WEIGHT

- (iv) Material used in the ROPS must have the capability of performing at zero degrees Fahrenheit, or exhibit Charpy V notch impact strength of 8 foot-pounds at minus 20 deg. Fahrenheit. This is a standard Charpy specimen as described in American Society of Testing and Materials A 370, Methods and Definitions for Mechanical Testing of Steel Products (available at each Regional Office of the Occupational Safety and Health Administration). The purpose of this requirement is to reduce the tendency of brittle fracture associated with dynamic loading, low temperature operation, and stress raisers which cannot be entirely avoided on welded structures.

FIGURE W-8

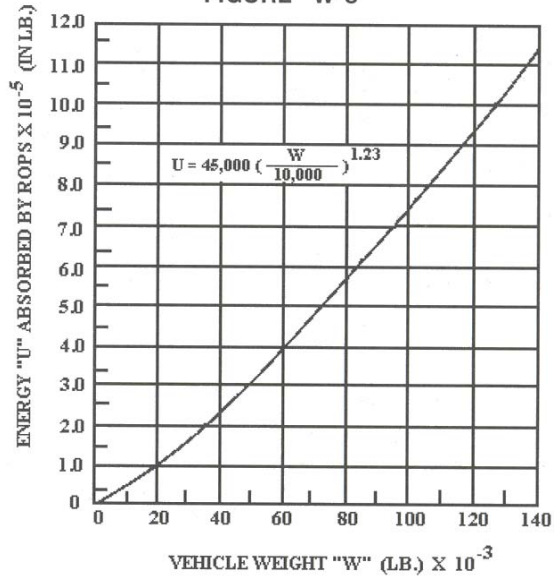

FIGURE W-8 - ENERGY ABSORBED VERSUS VEHICLE WEIGHT

FIGURE W-9

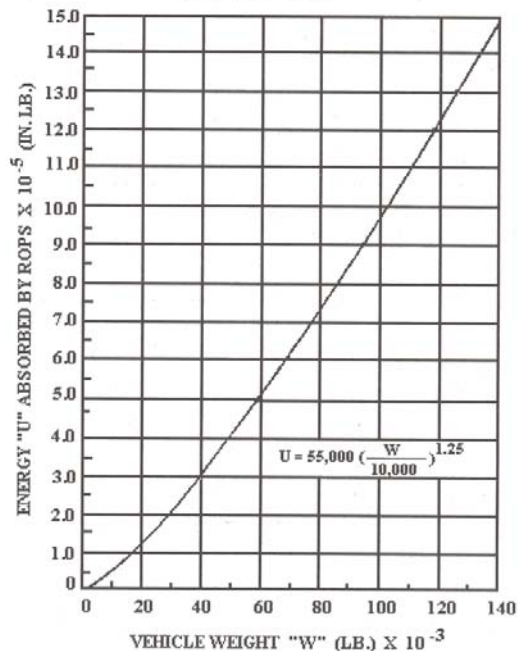

FIGURE W-9 - ENERGY ABSORBED VERSUS VEHICLE WEIGHT

(g) Definitions

For purposes of this section, "vehicle weight" means the manufacturer's maximum weight of the prime mover for rubber-tired self-propelled scrapers. For other types of equipment to which this section applies, "vehicle weight" means the manufacturer's maximum recommended weight of the vehicle plus the heaviest attachment.

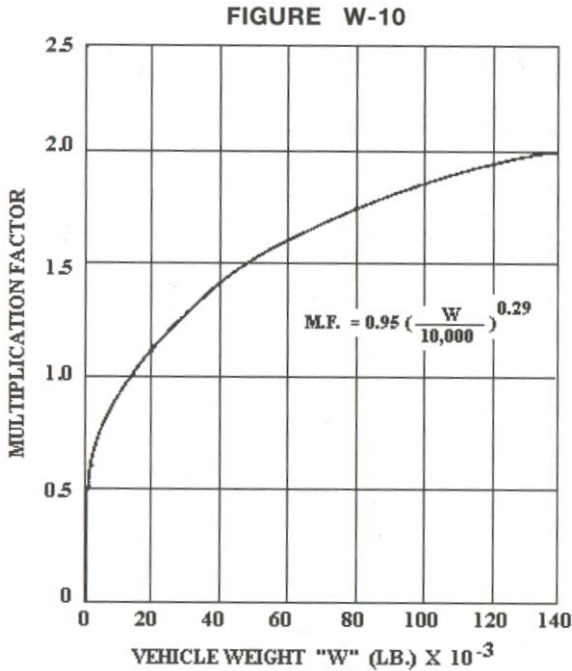

FIGURE W-10 - MINIMUM HORIZONTAL LOAD FACTOR FOR SELF-PROPELLED SCRAPERS.

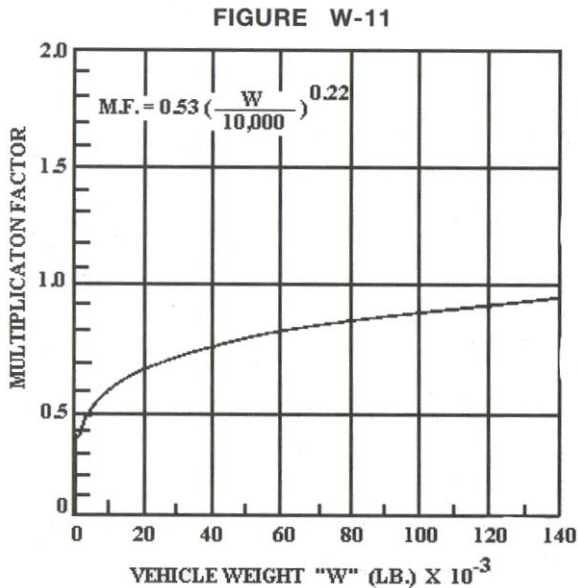

FIGURE W-11 - MINIMUM HORIZONTAL LOAD FACTOR FOR RUBBER-TIRES LOADERS AND DOZERS.

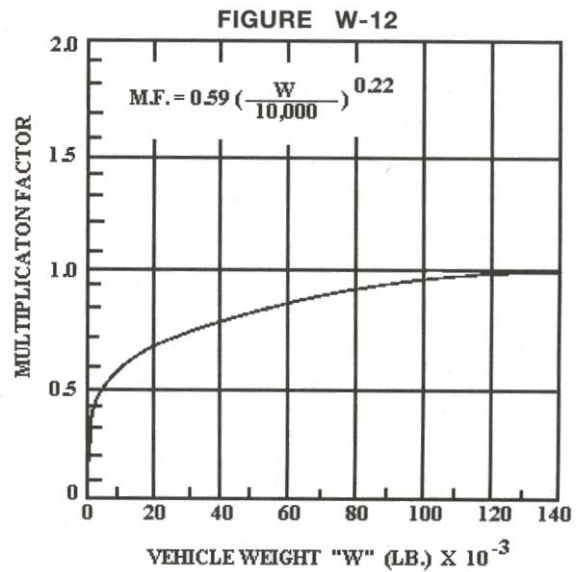

FIGURE W-12 - MINIMAL HORIZONTAL LOAD FACTOR FOR CRAWLER TRACTORS AND CRAWLER TYPE LOADERS.

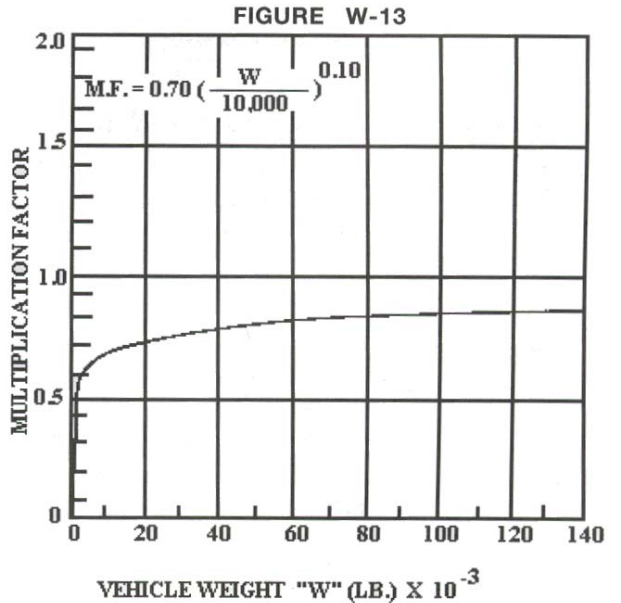

FIGURE W-13 - MINIMUM HORIZONTAL LOAD FACTOR FOR MOTOR GRADERS

(h) Source of standard

This standard is derived from, and restates, the following Society of Automotive Engineers Recommended Practices: SAE J320a, Minimum Performance Criteria for Roll-Over Protective Structure for Rubber-Tired, Self-Propelled Scrapers; SAE J394, Minimum Performance Criteria for Roll-Over Protective Structure for Rubber-Tired Front End Loaders and Rubber-Tired Dozers; SAE J395, Minimum Performance Criteria for Roll-Over Protective Structure for Crawler Tractors and Crawler-Type Loaders; and SAE J396, Minimum Performance Criteria for Roll-Over Protective Structure for Motor Graders. These recommended practices shall be resorted to in the event that questions of interpretation arise. The recommended practices appear in the 1971 SAE Handbook, which may be examined in each of the Regional Offices of the Occupational Safety and Health Administration.

1926.1002—PROTECTIVE FRAMES (ROLL-OVER PROTECTIVE STRUCTURES, KNOWN AS ROPS) FOR WHEEL-TYPE AGRICULTURAL AND INDUSTRIAL TRACTORS USED IN CONSTRUCTION

(a) General

- (1) The purpose of this section is to set forth requirements for frames for the protection of operators of wheel type agricultural and industrial tractors to minimize the possibility of operator injury resulting from accidental upsets during normal operation. With respect to agricultural and industrial tractors, the provisions of 29 CFR 1926.1001 and 1926.1003 for rubber-tired dozers and rubber-tired loaders may be utilized in lieu of the requirements of this section. These frames shall meet the test and performance requirements of the Society of Automotive Engineers Standard J334a-1970, Protective Frame Test Procedures and Performance Requirements, which is incorporated by reference. The incorporation by reference was approved by the Director of the Federal Register in accordance with 5 U.S.C. 552(a) and CFR part 51. Copies may be obtained from the Society of Automotive Engineers, 485 Lexington Avenue, New York, NY 10017. Copies may be inspected at the OSHA Docket Office, U.S. Department of Labor, 200 Constitution Avenue, NW, Room N2634, or at the Office of the Federal Register, 800 North Capitol Street, NW, Suite 700, Washington, D.C. The standard also appears in the 1971 SAE Handbook, which may be examined in each of OSHA's Regional Offices.
- (2) The protective frame which is the subject of this standard is a structure mounted to the tractor that extends above the operator's seat and conforms generally to Figure W-14.
- (3) If an overhead weather shield is attached to the protective frame, it may be in place during tests: Provided, that it does not contribute to the strength of the protective frame. If such an overhead weather shield is attached, it must meet the requirements of paragraph (i) of this section.

FIGURE W-14

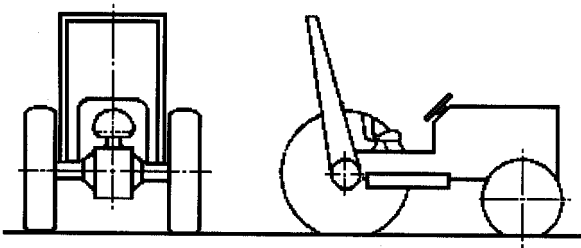

FIGURE W-14 -- Typical frame configuration.

- (4) For overhead protection requirements, see §§1926.1003.
- (5) If protective enclosures are used on wheel-type agricultural and industrial tractors, they shall meet the requirements of Society of Automotive Engineers Standard J168 (July 1970), Protective Enclosures, Test Procedures, and Performance Requirements. This standard appears in the 1971

SAE Handbook and may be examined in each Regional Office of the Occupational Safety and Health Administration.

(b) Applicability

The requirements of this section apply to wheel-type agricultural tractors used in construction work and to wheel-type industrial tractors used in construction work. See paragraph (j) of this section for definitions of agricultural tractors and industrial tractors.

(c) [Reserved]

(d) [Reserved]

(e) [Reserved]

(f) [Reserved]

(g) [Reserved]

(h) [Reserved]

(i) [Reserved]

(j) Definitions applicable to this section

- (1) SAE J333a, Operator Protection for Wheel-Type Agricultural and Industrial Tractors (July 1970) defines "agricultural tractor" as a "wheel-type vehicle of more than 20 engine horsepower designed to furnish the power to pull, carry, propel, or drive implements that are designed for agricultural usage." Since this Part 1926 applies only to construction work, the following definition of "agricultural tractor" is adopted for purposes of this subpart: "Agricultural tractor" means a wheel-type vehicle of more than 20 engine horsepower, used in construction work, which is designed to furnish the power to pull, propel, or drive implements.
- (2) "Industrial tractor" means that class of wheeled type tractor of more than 20 engine horsepower (other than rubber-tired loaders and dozers described in §§1926.1001), used in operations such as landscaping, construction services, loading, digging, grounds keeping, and highway maintenance.

1926.1003 — OVERHEAD PROTECTION FOR OPERATORS OF AGRICULTURAL AND INDUSTRIAL TRACTORS

(a) General

- (1) Purpose. When overhead protection is provided on wheel-type agricultural and industrial tractors, the overhead protection shall be designed and installed according to the requirements contained in the test and performance requirements of Society of Automotive Engineers Standard J167-1970, Protective Frame with Overhead Protection-Test Procedures and Performance Requirements, which pertains to overhead protection requirements and is incorporated by reference. The incorporation by reference was approved by the Director of the Federal Register in accordance with 5 U.S.C. 552(a) and 1 CFR part 51. Copies may be obtained from the Society of Automotive Engineers, 485 Lexington Avenue, New York, NY 10017, Copies may be inspected at the OSHA Docket Office, U.S. Department of Labor, 200 Constitution Ave., NW., Room N2634, or at the Office of the Federal Register, 800 North Capitol St., NW., Suite 700, Washington, D.C. The standard also appears in the 1971 SAE Handbook, which may be examined in each of OSHA's Regional Offices.

- (2)** Applicability. This standard applies to wheel-type agricultural tractors used in construction work and to wheel-type industrial tractors used in construction work. See 29 CFR 1926.1002 (b) and (j). In the case of machines to which 29 CFR 1926.604 (relating to site clearing) also applies, the overhead protection may be either the type of protection provided in 29 CFR 1926.604 or the type of protection provided by this section.

(b) Overhead protection

When overhead protection is installed on wheel-type agricultural or industrial tractors used in construction work, it shall meet the requirements of this paragraph. The overhead protection may be constructed of a solid material. If grid or mesh is used, the largest permissible opening shall be such that the maximum circle which can be inscribed between the elements of the grid or mesh is 1.5 in. (38 mm.) in diameter. The overhead protection shall not be installed in such a way as to become a hazard in the case of upset.



Michigan Occupational Safety and Health
Administration
PO Box 30643
Lansing, Michigan 48909-8143
Ph: 517.322.1845

The Department of Licensing and Regulatory Affairs will not discriminate against any individual or group because of race, sex, religion, age, national origin, color, marital status, disability, or political beliefs. Auxiliary aids, services and other reasonable accommodations are available upon request to individuals with disabilities.